

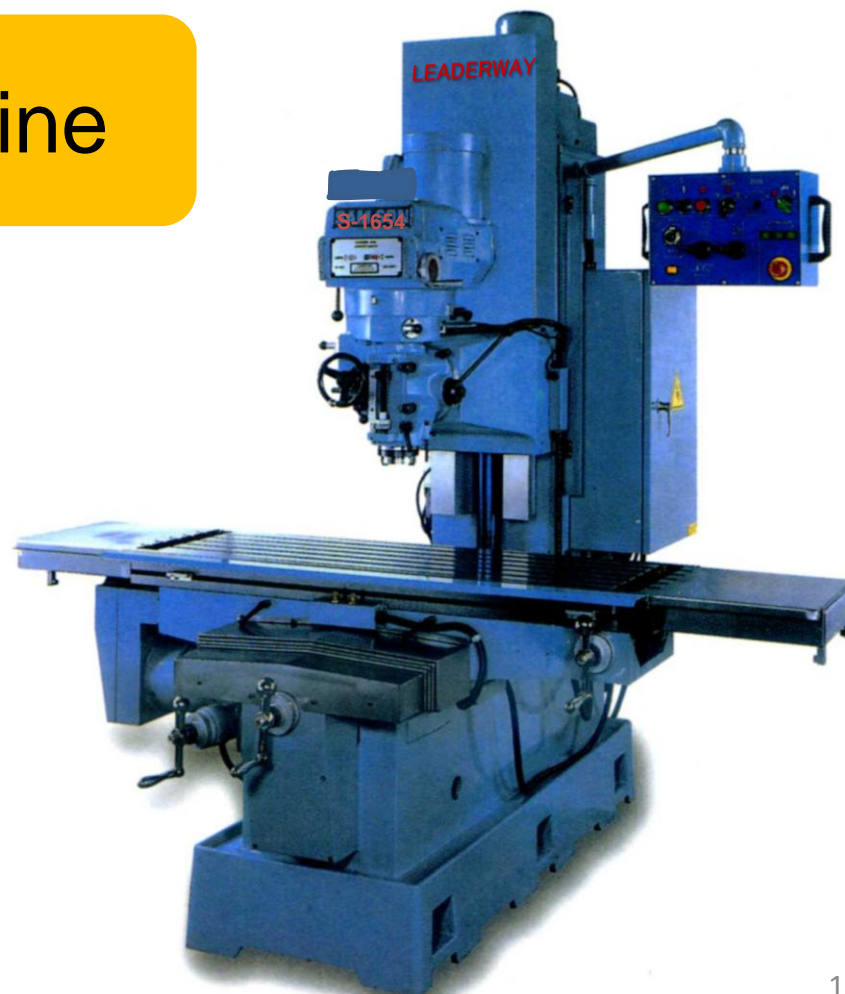

台灣力得衛宇龍科技(股)公司

LEADERWAY CNC TECHNOLOGIES, CO., LTD..

Vertical milling machine



特點：

- 採用米漢納高級鑄鐵。
- 橫向滑座及工作台，硬化及精密研磨。
- 鞍座X、Y滑座面加貼耐模板，使其滑動順暢、耐磨、減輕操作力、長時間操作不易疲勞。
- 傳動 system 可多用選擇。

S-1654

FEATURES:

- The main machine body is made from Meehanite casting.
- The saddle and table are hardened and ground.
- For long-lasting accuracy and smooth operation, "Turcite-B" is applied to the surface of the X and Y slideways.
- To forward system can choose many ways.

標準附件

- 拉桿
- 工具及工具箱
- 檔屑板
- 油壺
- 水平調整螺栓及墊塊
- 冷卻系統
- 工作箱
- X、Y、Z 三軸滾珠螺桿
- X、Y、Z 三軸 AC 馬達
- + 變頻器控制
- Y 軸前金屬護蓋

STANDARD ACCESSORIES:

- Draw bar.
- Tool and tool box.
- Chip cover.
- Oil pot.
- Level abgusting of bolts and blocks.
- Cooling system
- Working light
- X.Y.Z.spindle roll spiral shaft
- X.Y.Z.spindle A.C mator & frequency
- of waves control
- Y spindle front metal cover

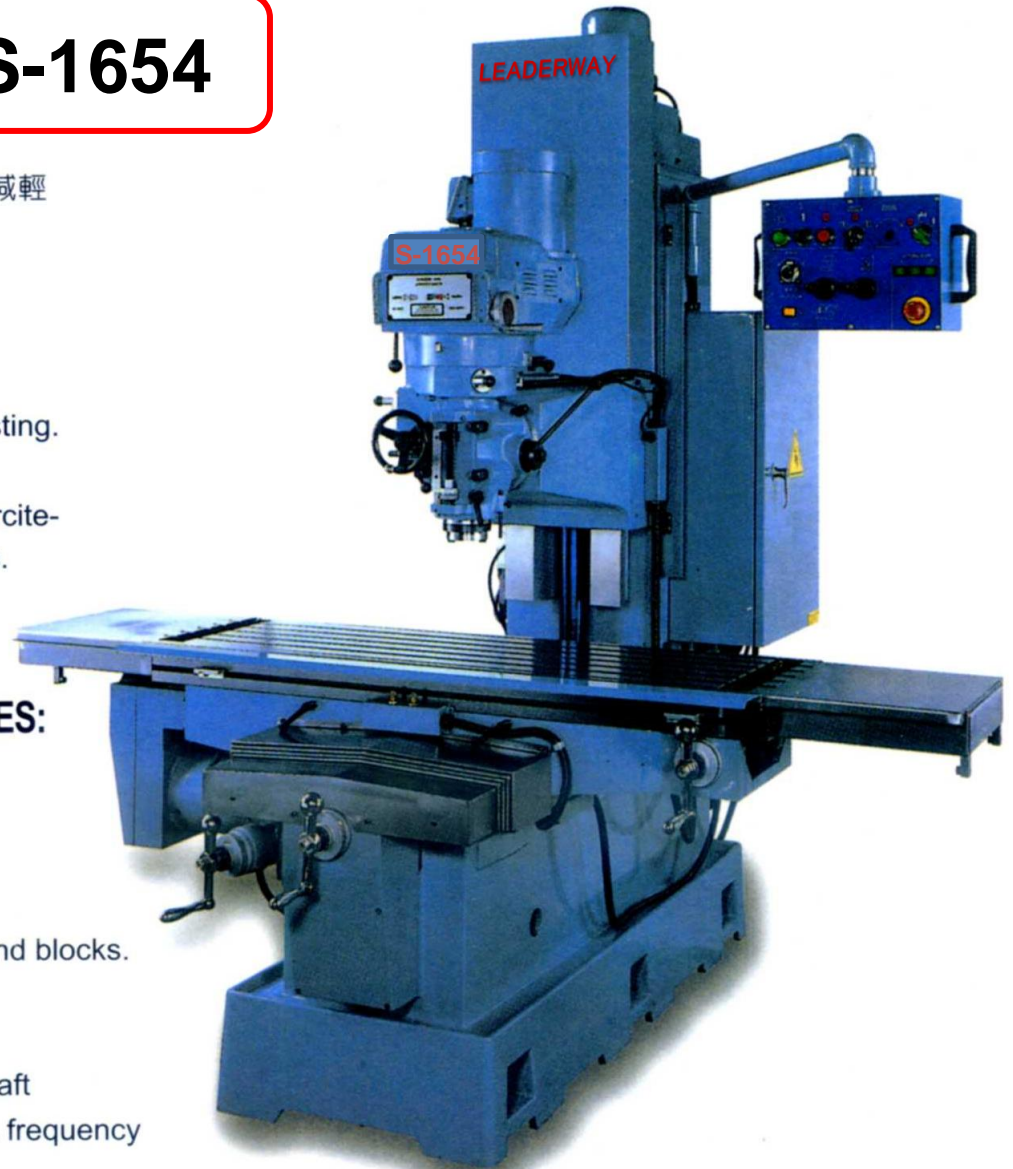



Vertical milling machine

S-1654

規 格		INCH	METRIC	機 械 尺 寸
工作台尺寸(長×寬)	Working table area (LxM)	16" x 54"	400 mm x 1370 mm	
最大負載	Max loading	1200 kgs. (2640 lbs.)		
T 一槽溝	T - slots	5 - 5/8"		
左右行程 (手動)	Longitudinal (Manual)	36"	1000 mm	
前後行程	Cross travel	20"	508 mm	
上下行程	Vertical travel	24"	610 mm	
排出管行程	Quill travel	6"	150 mm	
頭部旋轉角度	Head tilt	R or L 90 ° each		
主軸馬達	Spindle motor	5HP (3.75 kw)		
主軸速度	Speed	60 - 3600 rpm		
排出管直徑	Quill diameter	4 - 1/8"	105 mm	
主軸斜度	Spindle taper	NT 40 #		
軸面至工作台	Spindle nose to table	3.5"~24"	90~700 mm	
軸心至表面柱	Spindle center to column surface	21"	533 mm	
所需地面空間	Floor space required	113" x 71"	2875 mm x 1800 mm	
總高	Height	82 - 1/2"	2100 mm	
淨重	Weight	2400 kgs (5280 lbs.)		
電壓 (V)	Voltage	230 / 380 415 / 575		
冷卻泵馬達	Coolant pump	1/8 HP		
裝箱尺寸	1 Sets / Box	2250 x 1970 x 2250 mm		

- The manufacturer reserves the right to modify the design, mechanisms.....etc. to improve the performance of the machine without notice, all specifications shown above are just for reference.
- 本公司保有產品設計變更之權利。

5000VS

特點：

- 採用米漢納高級鑄鐵。
- 橫向滑座及工作台，硬化及精密研磨。
- 鞍座X、Y滑座面加貼耐磨板，使其滑動順暢、耐磨、減輕操作力、長時間操作不易疲勞。
- 主軸傳動機構採特殊設計，圓齒型皮帶，馬力極強。

FEATURES:

- The main machine body is made from Meehanite casting.
- The saddle and table are hardened elaborately ground.
- For long-lasting accuracy and smooth operation, "Turcite-B" is applied to the surface of the X and Y slideways.
- It is special design for driven mechanism power grip HTD belts provide positive and trouble free power transmission in low speed high torque applications and offer numerous advantages.

標準附件

- 冷卻系統
- X軸傳動箱機構
- X、Y軸貼Turcite-B
- 自動潤滑系統
- 工作台上、下傳動馬達
- 工具箱
- 電氣箱和操作盤

STANDARD ACCESSORIES:

- Cooling system.
- Power feed gear box for X-axis.
- Turcite-B on X, Y-axis.
- Automatic lubricator.
- Table elevating motor.
- Tool box.
- Electric control box and operation panel.





Vertical milling machine

5000VS

規 格		5000VS	機 械 尺 寸
工作台尺寸 (長×寬)	Working table area (LxM)	1500x300mm	
左右行程 (手動)	Longitudinal travel manual	1200MM(47 1/4")	
前後行程	Cross travel	380 mm(15")	
上下行程	Vertical travel of knee	500 mm(19 3/4")	
左右進給	Longitudinal power feed	12 steps 24-707 mm/min	
左右快速進給	Longitudinal rapid traverse	2400 mm/mm	
主軸速度	SPindle speeds	60-3600 r.p.m.(variable)	
主軸斜度	Spindle taper	NT #40	
頭部旋轉角度	Head tilting	90° right and left	
排出管行程	Quill travel	150 mm	
伸臂行程	Overarm travel	500 mm	
伸臂迴轉角度	Overarm swivel	360°	
主軸鼻端至工作台面距離	Distance from spindle nose to table surface	0-535 mm(21")	
主軸每轉進刀量	Quill feed per revolution of spindle	.04 .08 .13	
主軸馬達	Spindle motor	(5 HP)	
工作台左右馬達	Table longitudinal power	2HP	
工作台上馬達	Table vertical motor	1/2 HP 6P	
冷卻泵浦馬達	Coolant pump	1/8 HP	
淨重	Net weight	2250kg	
機器尺寸	Machine dimensions(LxWxH)	2100x2080x2400 mm	
包裝尺寸	Packing dimensions(LxWxH)	2200x1740x2040 mm	

- The manufacturer reserves the right to modify the design, mechanisms,....etc. to improve the performance of the machine without notice, all specifications shown above are just for reference.
- 本公司保有產品設計變更之權利。

特點：

- 採用米漢納高級鑄鐵。
- 橫向滑座及工作台，硬化及精密研磨。
- 鞍座X、Y滑座面加貼耐磨板，使其滑動順暢、耐磨、減輕操作力、長時間操作不易疲勞。
- 主軸傳動機構採特殊設計，圓齒型皮帶，馬力極強。

S-5A/S-5M

FEATURES:

- The main machine body is made from Meehanite casting.
- The saddle and table are hardened elaborately ground.
- For long-lasting accuracy and smooth operation, "Turcite-B" is applied to the surface of the X and Y slideways.
- It is special design for driven mechanism power gripHTD belts provide positive and trouble free power transmission in low speed high torque applications and offer numerous advantages.

標準附件

- 拉桿
- 工具及工具箱
- 檔屑板
- 油壺
- 水平調整螺栓及墊塊
- 電氣箱
- 工作台上傳動馬達

STANDARD ACCESSORIES:

- Cooling system.
- Power feed gear box for X-axis.
- Turcite-B on X,Y-axis.
- Automatic lubricator.
- Table elevating motor.
- Tool box.
- Electric control box and operation panel.

特別附件

- 冷卻系統
- 冷卻水盤
- 自動進給裝置
- 工作燈

SPECIAL ACCESSORIES:

- Cooling system.
- Coolant pan
- Automatic feed equipment
- Working light

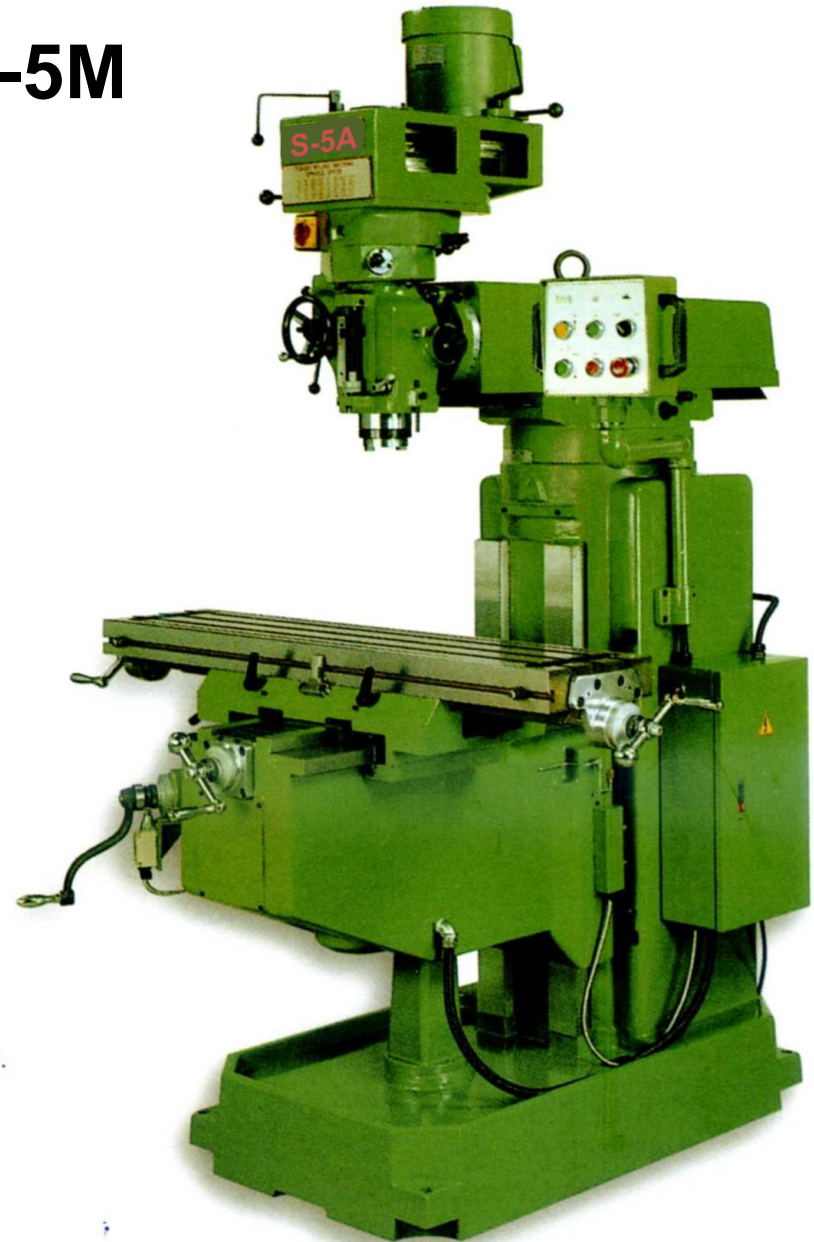

Vertical milling machine

S-5A/S-5M



規 格		S-5A	S-5M	機 械 尺 寸
工作台尺寸(長×寬)	Working table area (LxM)	1270 x 280 mm		
左右行程	Longitudinal travel manual / auto	740 mm / 600 mm		
前後行程	Cross travel	438 mm		
上下行程	Vertical travel of knee	460 mm		
主軸每分鐘轉速	Spindle speeds	Variable 60 - 3600 rpm	10 steps 65-2800 rpm	
主軸每轉進給速度	Quill feed per revolution of spindle	0.04 mm 0.08 mm 0.15 mm / rev		
主軸上下行程	Quill travel	127 mm or 150 mm		
主軸斜度	Spindle taper	NT 40		
主軸機頭旋轉角度	Swivel angle of head	right and left 90°, front and back 45°		
主軸馬達	Motor of spindle	5HP		
排出管外徑	Quill diameter	ø 105 mm		
總高	A. Overall height	2400 mm		
總長	B. Overall depth	2000 mm		
總寬	C. Overall width	2450 mm		
主軸至台面距離	D. Distance of spindle to table	70 -520 mm		
機械荷重	Machine load:	350 kg		
裝箱尺寸	Packing dimensions(LxWxH)	1720 x 1600 x 1900 mm		
淨重	Net weight	1600 kg		

- The manufacturer reserves the right to modify the design, mechanisms,....etc. to improve the performance of the machine without notice, all specifications shown above are just for reference.
- 本公司保有產品設計變更之權利。

S-3A/S-3M

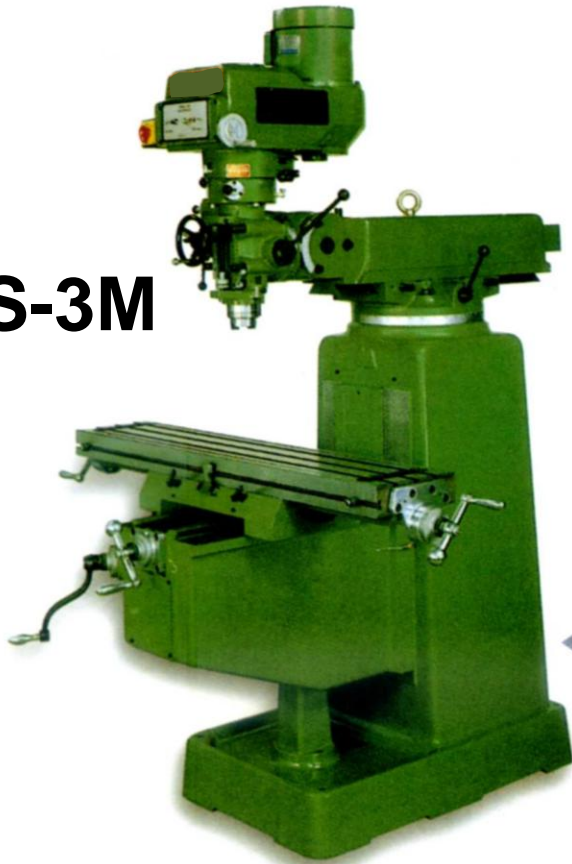

特點：

- 採用米漢納高級鑄鐵。
- 橫向滑座及工作台，硬化及精密研磨。
- 鞍座X、Y滑座面加貼耐磨板，使其滑動順暢、耐磨、減輕操作力、長時間操作不易疲勞。

·FEATURES:

- The main machine body is made from Meehanite casting.
- The saddle and table are hardened and ground.
- For long-lasting accuracy and smooth operation, "Turcite-B" is applied to the surface of the X and Y slideways.

◀ S-3A/S-3M

標準附件

- 拉桿
- 工具及工具箱
- 檔屑板
- 油壺

STANDARD ACCESSORIES:

- Draw bar.
- Tool and too box.
- Chip cover.
- Oil pot.

特別附件

- 冷卻系統
- 冷卻水盤
- 電氣箱
- 自動進給裝置
- 工作燈

SPECIAL ACCESSORIES:

- Cooling system.
- Cooant pan
- Electric control box.
- Automatic feed equipment
- Working light

S-3AII/S-3MII



◀ S-3AII/S-3MII

Vertical milling machine

S-3A/S-3M

S-3AII/S-3MII



規 格		S-3A	S-3A II	S-3M	S-3M II
主軸斜度	Taper of spindle nose	R8 or NT30#			
主軸速度	Spindle speeds (variable)	6-4200RPM		8 speeds 80-2720RPM 16 speeds 80-5440RPM	
排出管行程	Quill travel	127 mm (5")			
主軸每轉進給速度	Quill feed per revolution of spindle	0.04 mm(0.0012") 0.08 mm (0.003") 0.015 mm (0.006")/ rev			
頭部迴轉角度	Head swivel angle	Right and left 90 °, front and back 45°			
主軸馬達	Motor of spindle	3 HP			
工作台尺寸	Table working size	254 x 1270 mm (10"x50")			
左右行程	Longitudinal travel	manual 910mm(36") auto 840 mm (33")			
前後行程	Cross travel	406 mm (16")			
上下行程	Vertical travel of knee	406 mm (16")			
伸臂行程	Overarm travel	550 mm (22")			
淨重	Net weight	1200 kg			

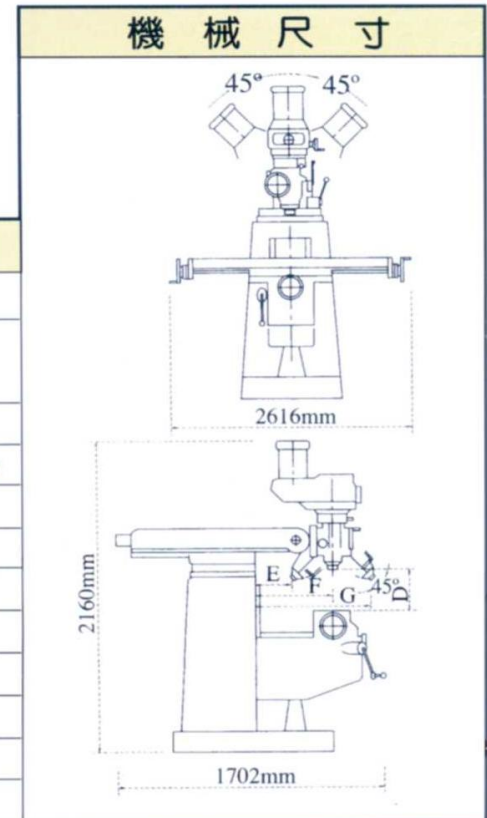

- The manufacturer reserves the right to modify the design, mechanisms,.....etc. to improve the performance of the machine without notice, all specifications shown above are just for reference.
- 本公司保有產品設計變更之權利。

S-2A/S-2M

特點：

- 採用米漢納高級鑄鐵。
- 橫向滑座及工作台，硬化及精密研磨。
- 鞍座X、Y滑座面加貼耐磨板，使其滑動順暢、耐磨、減輕操作力、長時間操作不易疲勞。

FEATURES:

- The main machine body is made from Meehanite casting.
- The saddle and table are hardened and ground.
- For long-lasting accuracy and smooth operation, "Turcite-B" is applied to the surface of the X and Y slideways.

標準附件

- 拉桿
- 工具及工具箱
- 檔屑板
- 油壺

STANDARD ACCESSORIES:

- Draw bar.
- Tool and tool box.
- Chip cover.
- Oil pot.

特別附件

- 冷卻系統
- 冷卻水盤
- 電氣箱
- 自動進給裝置
- 工作燈

SPECIAL ACCESSORIES:

- Cooling system.
- Coolant pan
- Electric control box.
- Automatic feed equipment
- Working light





Vertical milling machine

S-2A/S-2M

規 格		S-2A	S-2M	機 械 尺 寸
工作台尺寸(長×寬)	Working table area (LxM)	1070 x 230 mm		
左右行程	Longitudinal travel manual / auto	680mm		
前後行程	Cross travel	305mm		
上下行程	Vertical travel of knee	405mm		
主軸每分鐘轉速	Spindle speeds	Variable 60 - 4200 rpm	8 steps 80-2750 rpm	
主軸每轉進給速度	Quill feed per revolution of spindle	0.04 mm 0.08 mm 0.15 mm / rev		
主軸上下行程	Quill travel	127 mm		
主軸斜度	Spindle taper	R8 or NT 30		
主軸機頭旋轉角度	Swivel angle of head	Right and left 90°, front and back 45°		
主軸馬達	Motor of spindle	3 HP	2 HP	
主軸外徑	Quill diameter	85.75 mm		
總高	A. Overall height	2236mm		
總長	B. Overall depth	1623 mm		
總寬	C. Overall width	1480 mm		
主軸至台面距離	D. Distance of spindle to table	43-468 mm		
機械荷重	Machine load.	300 kg		
裝箱尺寸	Packing dimensions(LxWxH)	165cm X 138cm		
淨重	Net weight	900 kg		

- The manufacturer reserves the right to modify the design, mechanisms,....etc. to improve the performance of the machine without notice, all specifications shown above are just for reference.
- 本公司保有產品設計變更之權利。

特點：

- 採用米漢納高級鑄鐵。
- 橫向滑座及工作台，硬化及精密研磨。
- 鞍座X、Y滑座面加貼耐磨板，使其滑動順暢、耐磨、減輕操作用力、長時間操作不易疲勞。

S-4A/S-4M

FEATURES:

- The main machine body is made from Meehanite casting.
- The saddle and table are hardened and ground.
- For long-lasting accuracy and smooth operation, "Turcite-B" is applied to the surface of the X and Y slideways.

標準附件

- 拉桿
- 工具及工具箱
- 檔屑板
- 油壺
- 水平調整螺栓及墊塊

STANDARD ACCESSORIES:

- Draw bar.
- Tool and tool box.
- Chip cover.
- Oil pot.
- Level adjusting of bolts and blocks.

特別附件

- 冷卻系統
- 冷卻水盤
- 電氣箱
- 自動進給裝置
- 工作燈

SPECIAL ACCESSORIES:

- Cooling system.
- Coolant pan
- Electric control box.
- Automatic feed equipment
- Working light

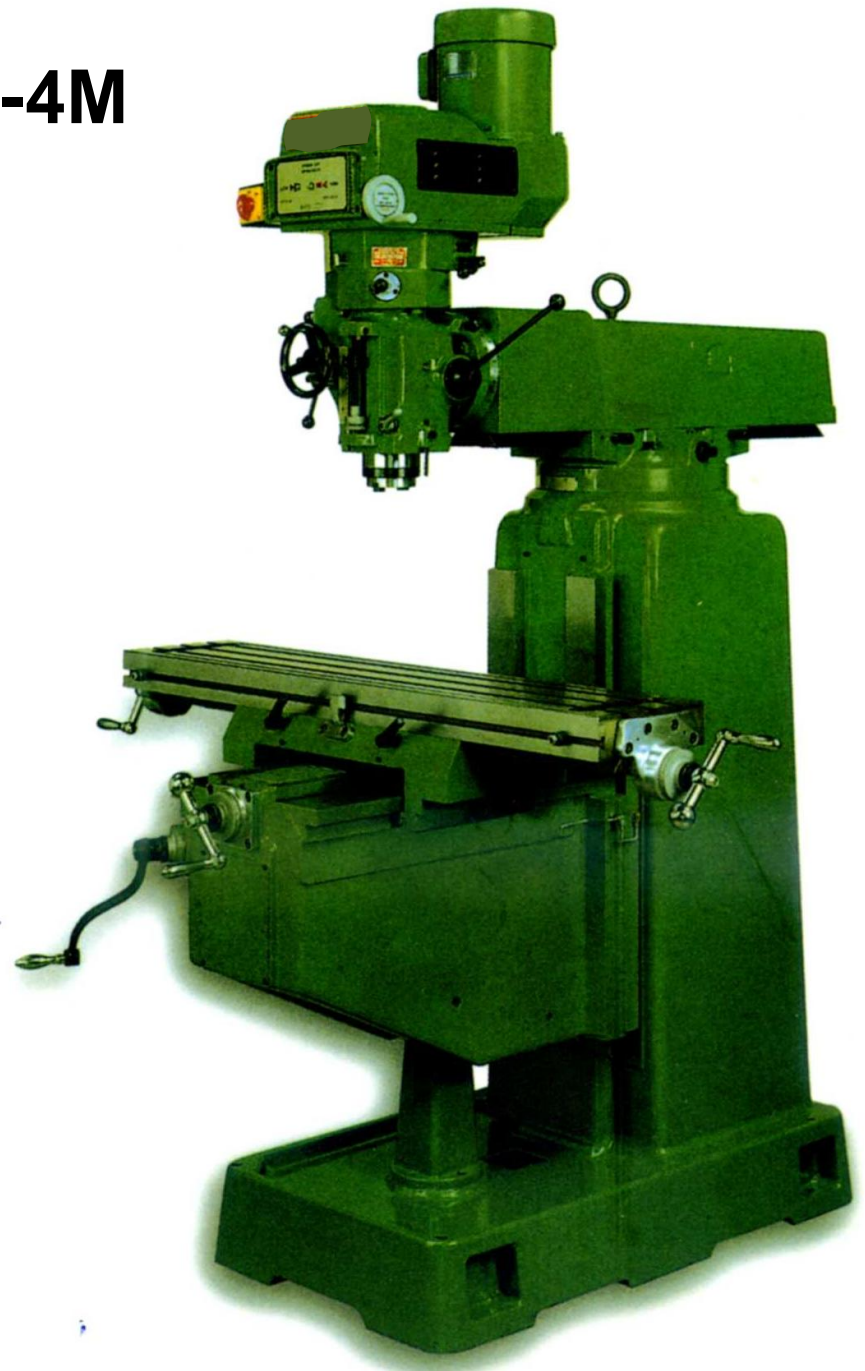

Vertical milling machine

S-4A/S-4M



規 格		S-4A	S-4M	機 械 尺 寸
工作台尺寸(長×寬)	Working table area (LxM)	1270 x 254 mm		
左右行程	Longitudinal travel manual / auto	780 mm 700 mm		
前後行程	Cross travel	430 mm		
上下行程	Vertical travel of knee	460 mm		
主軸每分鐘轉速	Spindle speeds	Variable 60 - 3600 rpm	10 steps 65-2800 rpm (4P)	
主軸每轉進給速度	Quill feed per revolution of spindle	0.04 mm 0.08 mm 0.15 mm / rev		
主軸上下行程	Quill travel	127 mm or 150 mm		
主軸斜度	Spindle taper	NT 40		
主軸機頭旋轉角度	Swivel angle of head	right and left 90°, front and back 45°		
主軸馬達	Motor of spindle	5HP		
主軸外徑	Quill diameter	ø 100 mm or ø 105 mm		
總高	A. Overall height	2300 mm		
總長	B. Overall depth	1900 mm		
總寬	C. Overall width	2450 mm		
主軸至台面距離	D. Distance of spindle to table	70 - 520 mm		
機械荷重	Machine load:	350 kg		
裝箱尺寸	Packing dimensions(LxWxH)	1720 x 1600 x 1900 mm		
淨重	Net weight	1500 kg		

- The manufacturer reserves the right to modify the design, mechanisms,....etc. to improve the performance of the machine without notice, all specifications shown above are just for reference.
- 本公司保有產品設計變更之權利。



Thanks for your attentions.

